

MERIDA

Team SL 1P-Cockpit

1

New MERIDA One-piece carbon Cockpit with fully integrated cable routing

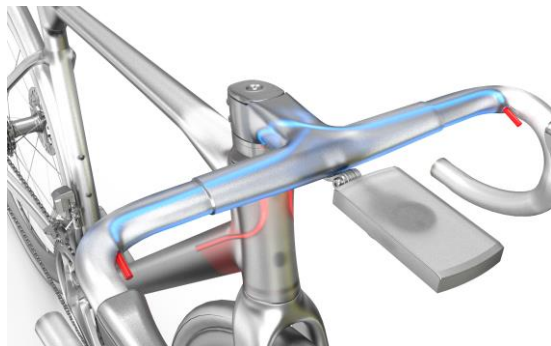

Manual V2021-10-14

MERIDA INDUSTRY CO., LTD
P.O. BOX 56 YUANLIN TAIWAN R.O.C.
PHONE: +886-4-8526171 FAX: +886-4-8527881

MERIDA R&D CENTER GMBH
BLUMENSTRASSE 49-51
D-71106 MAGSTADT

www.MERIDA-BIKES.com

Team SL 1P-Cockpit – Assembly drawing

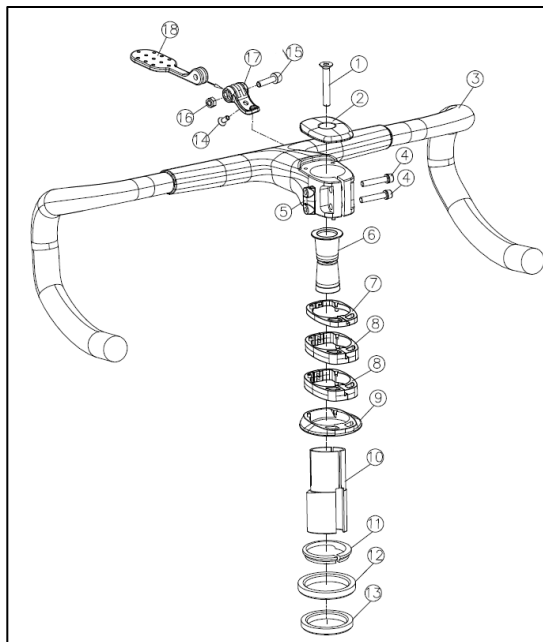

1	Headset Preload Bolt M6*35
2	Topcap
3	Team SL 1P cockpit
4	Bolt M5*26
5	Thread Plate
6	Expander / Steerer tube plug
7	Spacer 5mm
8	Spacer 10mm
9	Neck
10	Steerer shim
11	Compression Ring
12	Upper headset bearing [MH-P16, 52x7x45°]
13	Lower headset bearing
14	Countersunk Bolt M4*10
15	Bolt M5*18
16	Nut M5*5L
17	Computer Mount - H-bar adapter
18	Computer Mount - Front arm

MERIDA INDUSTRY CO., LTD
P.O. BOX 56 YUANLIN TAIWAN R.O.C.
PHONE: +886-4-8526171 FAX: +886-4-8527881

MERIDA R&D CENTER GMBH
BLUMENSTRASSE 49-51
D-71106 MAGSTADT

MERIDA

Team SL 1P-Cockpit - Geometry

3

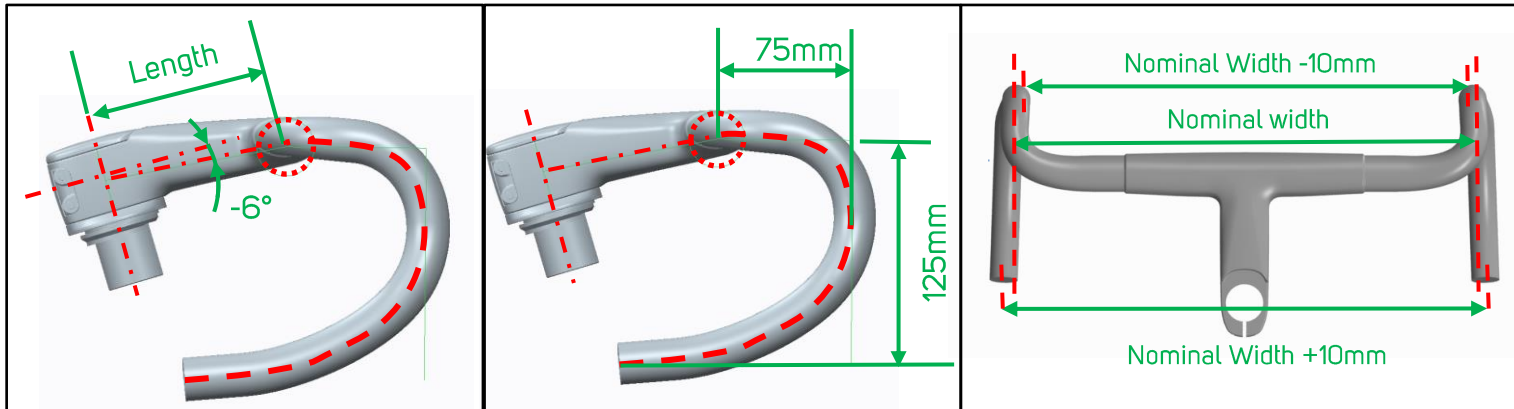

Stem Length: 90, 100, 110, 120, 130mm	Reach: 75mm	Nominal width: 400, 420, 440 mm (measured center to center).
Stem angle: -6°	Drop: 125mm	

MERIDA INDUSTRY CO., LTD
P.O. BOX 56 YUANLIN TAIWAN R.O.C.
PHONE: +886-4-8526171 FAX: +886-4-8527881

MERIDA R&D CENTER GMBH
BLUMENSTRASSE 49-51
D-71106 MAGSTADT

MERIDA

Team SL 1P-Cockpit - Geometry

4

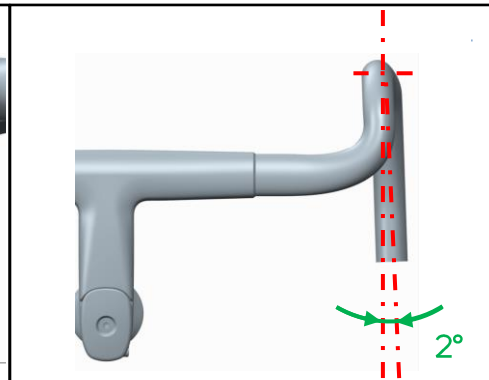
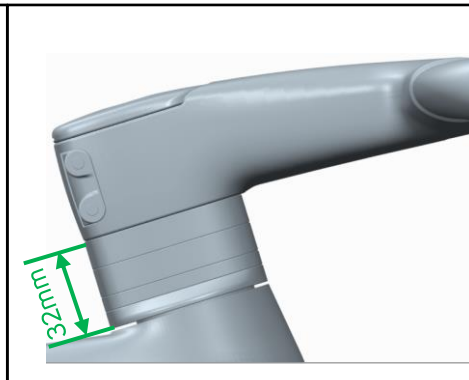
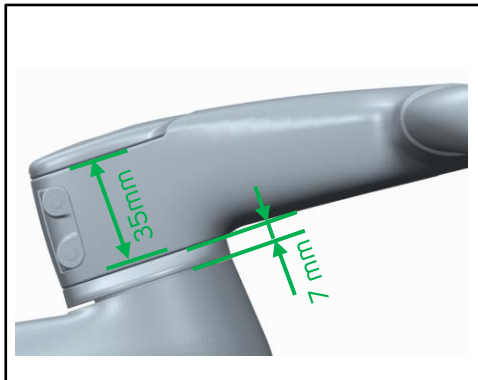

Min Stack height: 7mm between headtube upper edge and stem lower side. Clamping height of stem: 35mm.

Max Stack height: 32mm between headtube upper edge and stem lower side.

Flare: 2°

MERIDA INDUSTRY CO., LTD
P.O. BOX 56 YUANLIN TAIWAN R.O.C.
PHONE: +886-4-8526171 FAX: +886-4-8527881

MERIDA R&D CENTER GMBH
BLUMENSTRASSE 49-51
D-71106 MAGSTADT

MERIDA

Team SL 1P-Cockpit – Steerer Shim

5

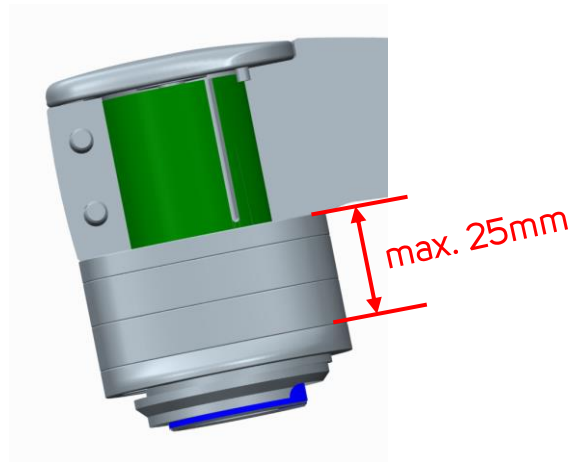
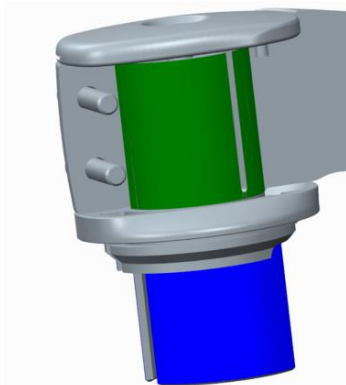
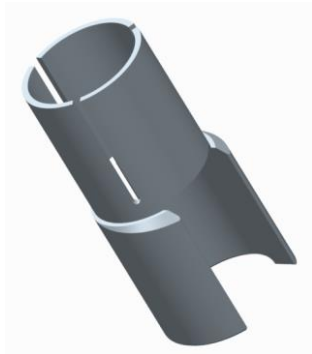

One of the key features of your MERIDA Team SL 1P cockpit is the steerer shim. It increases steerer safety and durability. It consists basically of 2 main areas: stem clamping area [green] and lower area [blue] that is in contact with the headset components and allows fully internal cable routing.

To assure proper function, it is necessary that the shim is positioned correctly. Lower part must always exceed the compression ring – that's why the maximum amount of spacers is limited to 25mm underneath the stem.

MERIDA INDUSTRY CO., LTD
P.O. BOX 56 YUANLIN TAIWAN R.O.C.
PHONE: +886-4-8526171 FAX: +886-4-8527881

MERIDA R&D CENTER GMBH
BLUMENSTRASSE 49-51
D-71106 MAGSTADT

MERIDA

Team SL 1P-Cockpit – Assembly preparation

6

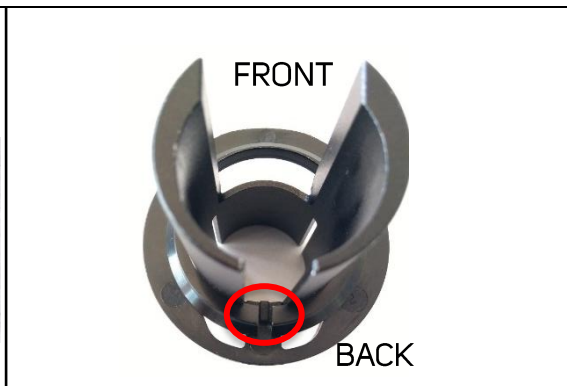

Pre-assemble compression ring [11], neck [9], (if needed spacers [7 & 8]) and shim [10] by sliding the shim from top side through spacers, neck and compression ring.

Check the correct positioning of the parts: The neck [9] has a little pin at rear side that must be positioned in the slice of the compression ring [11] (red circle). The big cut-out in shim is for cable-routing and has to point towards front side.

Hint: If you use spacers, a sticky tape during assembly might make assembly easier.

MERIDA INDUSTRY CO., LTD
P.O. BOX 56 YUANLIN TAIWAN R.O.C.
PHONE: +886-4-8526171 FAX: +886-4-8527881

MERIDA R&D CENTER GMBH
BLUMENSTRASSE 49-51
D-71106 MAGSTADT

MERIDA

Team SL 1P-Cockpit – Steerer length for use w/o spacers above stem

7

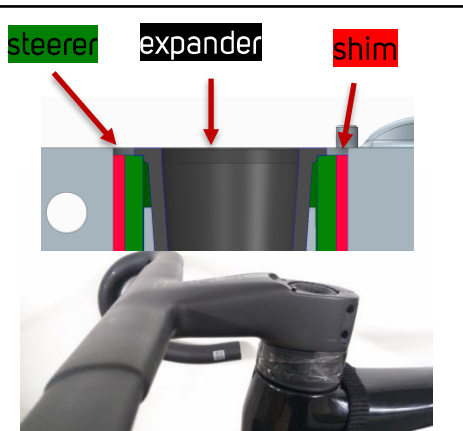

Assemble bearings, compression ring, neck and desired amount of spacers (max. 25mm) like described above.

You can use shim upper edge for the saw mark – then steerer (green) and shim (magenta) end ~1mm underneath stem upper edge.

In this case, when assembled with expander [6], expander upper edge is at same height as stem upper edge or a little bit above. This is correct steerer length.

MERIDA INDUSTRY CO., LTD
P.O. BOX 56 YUANLIN TAIWAN R.O.C.
PHONE: +886-4-8526171 FAX: +886-4-8527881

MERIDA R&D CENTER GMBH
BLUMENSTRASSE 49-51
D-71106 MAGSTADT

MERIDA

Team SL 1P-Cockpit – Steerer length for use with spacers above stem

8



Alternatively, if you don't know exactly your desired height of h-bar/stem, you can also keep the steerer longer and assemble spacers above the stem:

For easier installation, it is recommended to tape the single parts of the spacer together during assembly and remove the tape once the stem is clamped.

Hint: Due to the separable spacer design, you can switch spacers from above the stem to below the stem without disassembling the stem.

MERIDA INDUSTRY CO., LTD
P.O. BOX 56 YUANLIN TAIWAN R.O.C.
PHONE: +886-4-8526171 FAX: +886-4-8527881

MERIDA R&D CENTER GMBH
BLUMENSTRASSE 49-51
D-71106 MAGSTADT

MERIDA

Team SL 1P-Cockpit – Assembly step by step

9

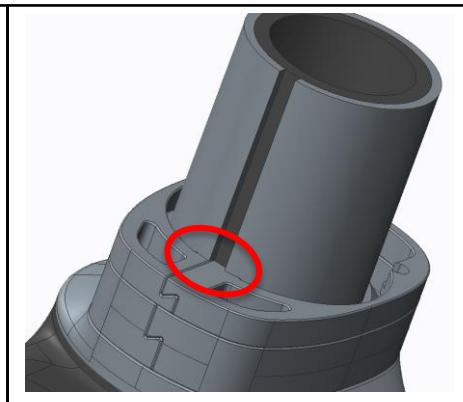
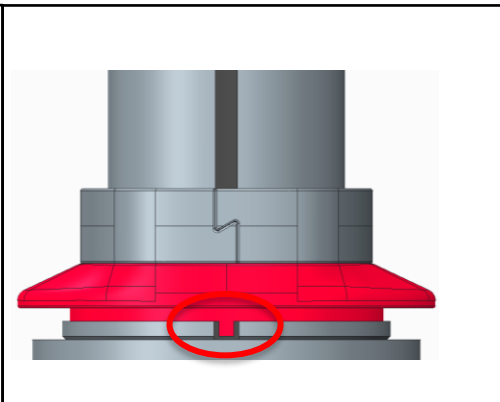

Slide the pre-assembled package of shim, compression ring, neck and possible spacers on the steerer tube. Guide the brake hoses through the opening in front of the shim.

Check again that neck [9] and compression ring [11] are still positioned correctly – the neck [9] has a little pin at lower side that must be positioned in between the gap at backside of compression ring [11].

Also it is important that the shim [10] is positioned correctly – the slot at rear side should attach to step of the spacer or neck.

MERIDA INDUSTRY CO., LTD
P.O. BOX 56 YUANLIN TAIWAN R.O.C.
PHONE: +886-4-8526171 FAX: +886-4-8527881

MERIDA R&D CENTER GMBH
BLUMENSTRASSE 49-51
D-71106 MAGSTADT

MERIDA

Team SL 1P-Cockpit – Assembly step by step

10

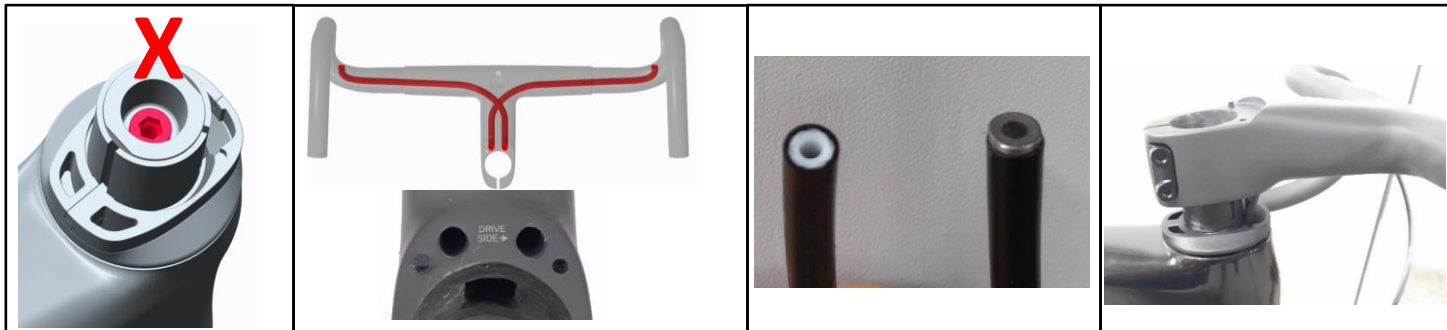

HINT: Do not tighten the expander plug before sliding the shim and stem over the steerer – this will help to get all parts slid in correct position more easily.

For easier cable routing through the h-bar, MERIDA TEAM SL 1P cockpit features bonded-in tubes. Note that these tubes cross each other inside the bar. The brake hose entry marked with 'DRIVE SIDE ->' leads to drive side STI.

Guide the brake hoses through the h-bar. In case there are difficulties, it might help to guide the brake hose without the insert-pin through the bar.

Slide the stem over the shim. Pull out the brake hoses at STI opening from time to time.

MERIDA INDUSTRY CO., LTD
P.O. BOX 56 YUANLIN TAIWAN R.O.C.
PHONE: +886-4-8526171 FAX: +886-4-8527881

www.MERIDA-BIKES.com

MERIDA R&D CENTER GMBH
BLUMENSTRASSE 49-51
D-71106 MAGSTADT

MERIDA

Team SL 1P-Cockpit – Assembly step by step

11

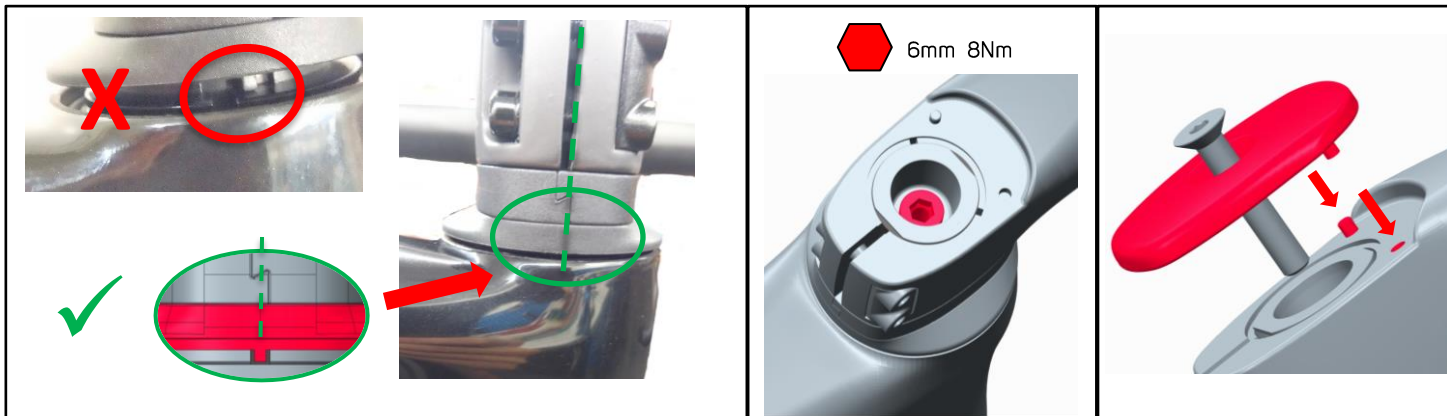

Before tightening the preload bolt, assure the compression ring [11], neck [9], optionally spacers [7, 8] and steerer shim [10] are still correctly positioned. The slice in compression ring needs to point backward and the pin of the neck must engage in this gap. The gap between neck and frame is <math><1\text{mm}</math>.

Once all parts are positioned correctly, install the fork steerer expander plug. Tighten the bolt to max. 8Nm.

Install the topcap [2]. Assure the 2 pins are positioned correctly.

MERIDA INDUSTRY CO., LTD
P.O. BOX 56 YUANLIN TAIWAN R.O.C.
PHONE: +886-4-8526171 FAX: +886-4-8527881

www.MERIDA-BIKES.com

MERIDA R&D CENTER GMBH
BLUMENSTRASSE 49-51
D-71106 MAGSTADT

MERIDA

Team SL 1P-Cockpit – Assembly step by step

12

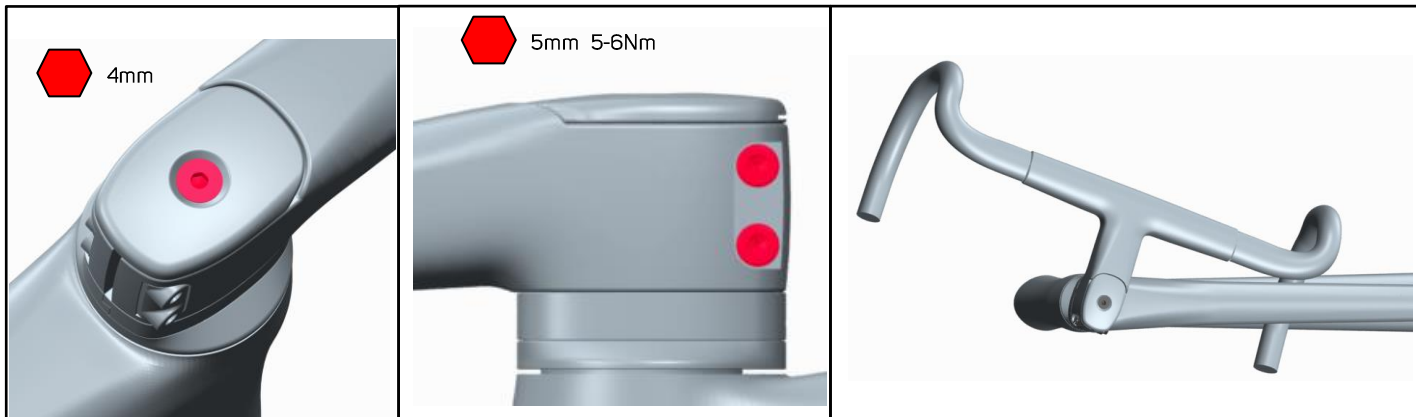

Adjust headset bearing play by slightly tighten the headset preload bolt [1]

Tighten the clamping bolts evenly to 5-6 Nm by turning each a quarter to half turn and then switch to other bolt. Use a torque wrench!

Rotate h-bar to maximum position to assure rear brake hose is long enough. Cut brake hoses to correct length and install following instructions of the brake manufacturer.

MERIDA INDUSTRY CO., LTD
P.O. BOX 56 YUANLIN TAIWAN R.O.C.
PHONE: +886-4-8526171 FAX: +886-4-8527881

www.MERIDA-BIKES.com

MERIDA R&D CENTER GMBH
BLUMENSTRASSE 49-51
D-71106 MAGSTADT

MERIDA

Team SL 1P-Cockpit – Computer Mount Installation

13

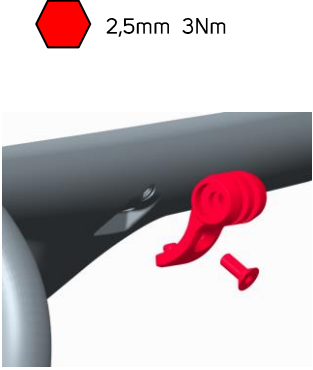
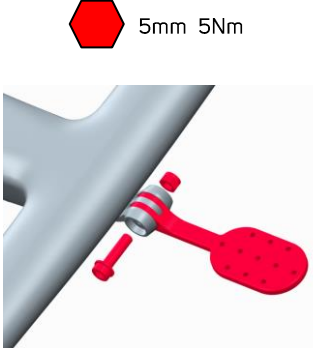
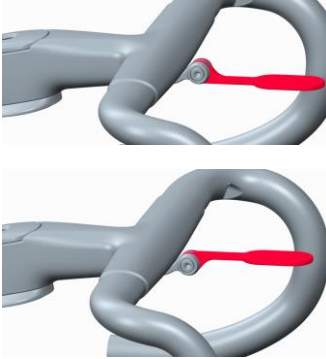
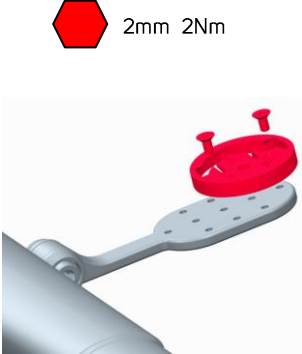
 <p>2,5mm 3Nm</p>	 <p>5mm 5Nm</p>		 <p>2mm 2Nm</p>
<p>Fix the h-bar adapter [17] with countersunk screw [14]. Tighten with 3Nm.</p>	<p>Slide the front arm [18] into the hinge and assemble with bolt [15] and nut [16]. Rotate to your preferred position and tighten the bolt with 5Nm.</p>	<p>The front arm [18] could be assembled in a higher and lower position.</p>	<p>Install your Computer mount in your desired position and tighten to ~2Nm.</p>

MERIDA INDUSTRY CO., LTD
P.O. BOX 56 YUANLIN TAIWAN R.O.C.
PHONE: +886-4-8526171 FAX: +886-4-8527881

www.MERIDA-BIKES.com

MERIDA R&D CENTER GMBH
BLUMENSTRASSE 49-51
D-71106 MAGSTADT